

# 3 OUTLET DISTRIBUTION BOX

ITEM #A-201  
WEIGHT - 100 LBS

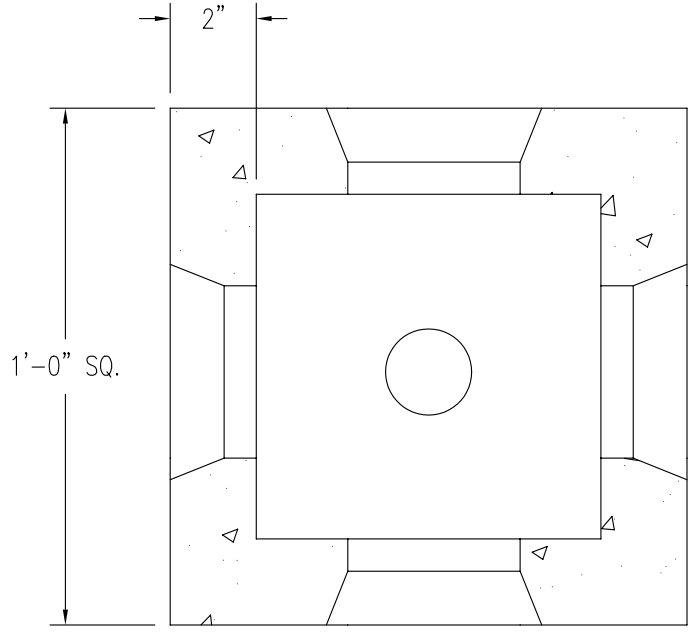

TOP VIEW

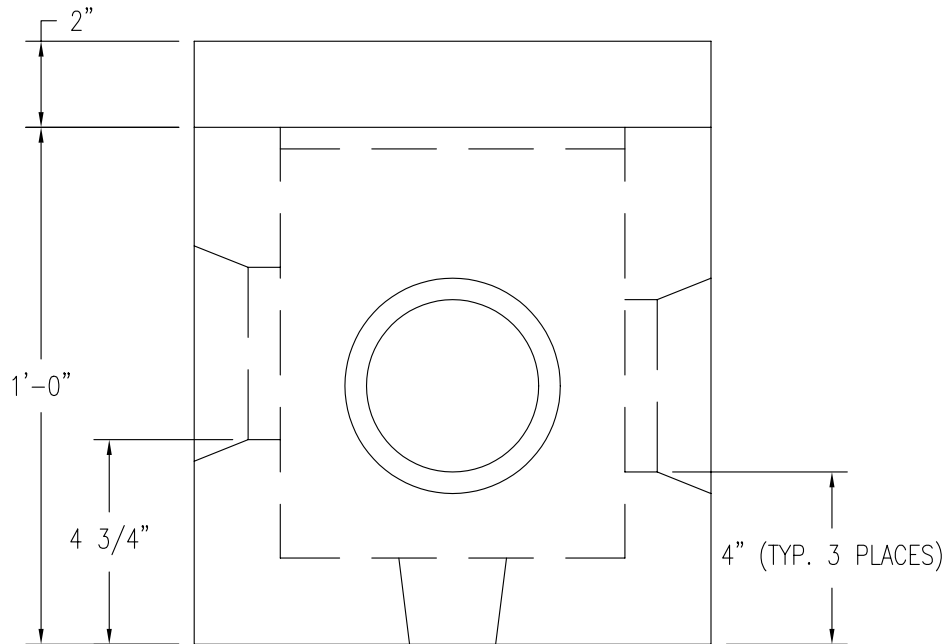

FRONT VIEW

## DESIGN NOTES:

- 1 - CONCRETE 4000 PSI AT 28 DAYS.
- 2 - EQUALIZERS AVAILABLE.